



EasyGate Superb

Type

Swing technology
1 wing / 2 wings
Round front

Safety & Security Detection

24 pairs of IR sensors
Adjustable Safety & Security levels
Tailgating / Cross over detection

Dimensions

Cabinet height	38.39"	990 mm
Cabinet length	55.12"	1400 mm
Cabinet Width	5.95"	99 mm
Barrier height standard	38.98"	990 mm
Barrier height max.	70.87"	1800 mm
Passage width standard[1]	25.59"	650 mm
Passage width max.[1]	36.22"	920 mm

Special features*

Arc layout



EasyGate Superb / 39" 990 mm



EasyGate Superb / 71" 1800 mm

* Optional [1] For 2 wings type

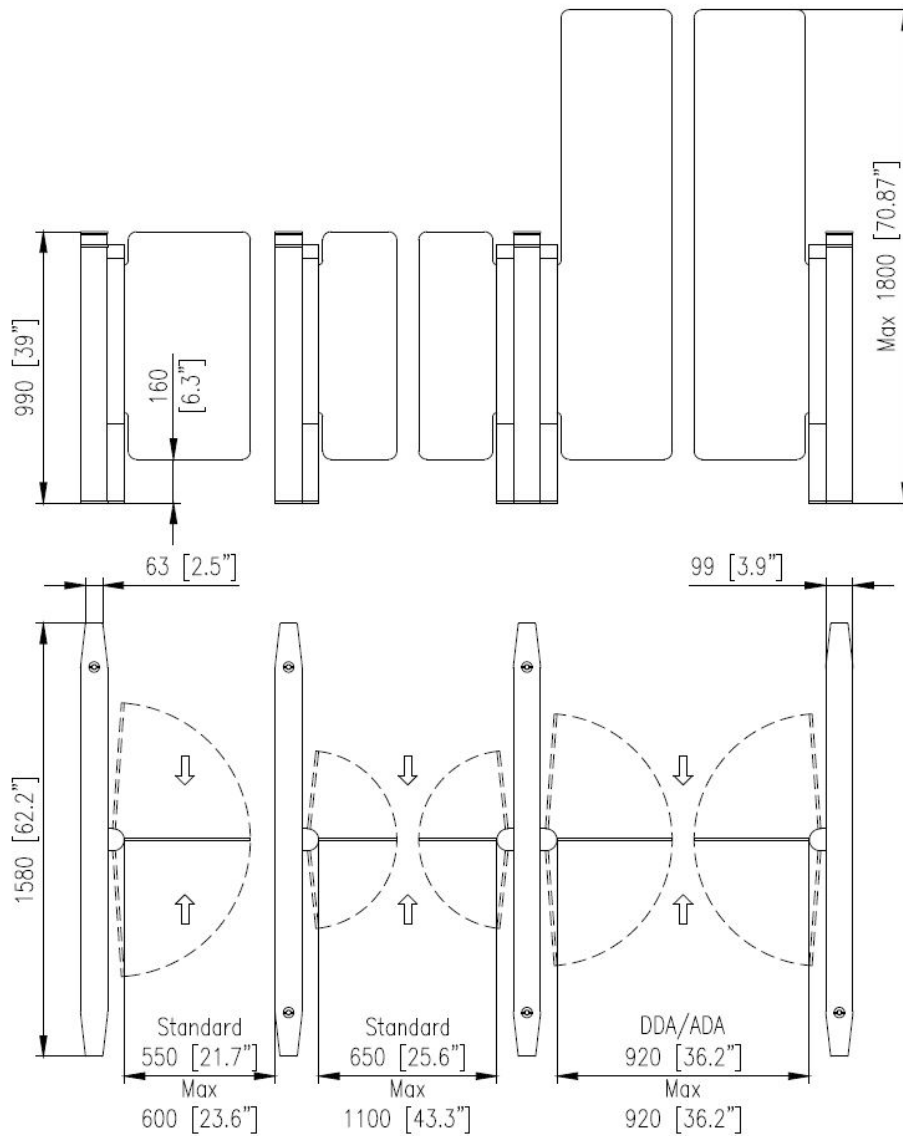

Operating Environment

Indoor

Drive Mechanism

Fail Safe

MCBF 5,000,000

Power Supply

110 AC, 60 Hz

Emergency Mode

Open automatically in the exit direction

Optional Accessories

- RFID reader bracket (flush mounted)
- Access Light / Lane Light / Passage Light
- WAV player
- Pressure sensing top
- RF remote control
- EasyTouch / TouchPanel / T-MON SW
- SuperCap (emergency power back-up)
- Alternative surface finishes / Optional top finishes
- Integration of LiftCall / Card collector / BarCode scanner
- Surface Mounting Bases

Material and Colours

Covers	brushed stainless steel	
Top Lid	black glass	
Barriers	tempered glass barrier panels	(0.39"/10mm)
Side infill panel	tempered glass panels	(0.24"/6mm)

